

## Automotive Lamp Outage Monitor

### Description

The IC U2480B is designed for individual monitoring of 11 lamps in automobiles. Three double comparators and five single comparators, which can be optionally inter-

connected, permit realization of many monitoring variants. An integrated latch is available to memorize the outage of indicator or brake lamps.

### Features

- 10 mV comparator thresholds
- Temperature compensated
- Voltage characteristic of the lamps is taken into account
- Input voltage range up to 23 V independent of supply
- Typical input currents 25  $\mu$ A, so that protective resistors can be connected in series
- Internal protection measures for pulses according to ISO TR 7637/1
- ESD according to MIL-SID-883 C test method 3015.7
  - Human body model: 4 kV
  - Machine model: 200 V
- EMI protection (TEM cell up to 100 V/m)

### Ordering Information

Extended Type Number	Package	Remarks
U2480B	SDIP28	

### Block Diagram

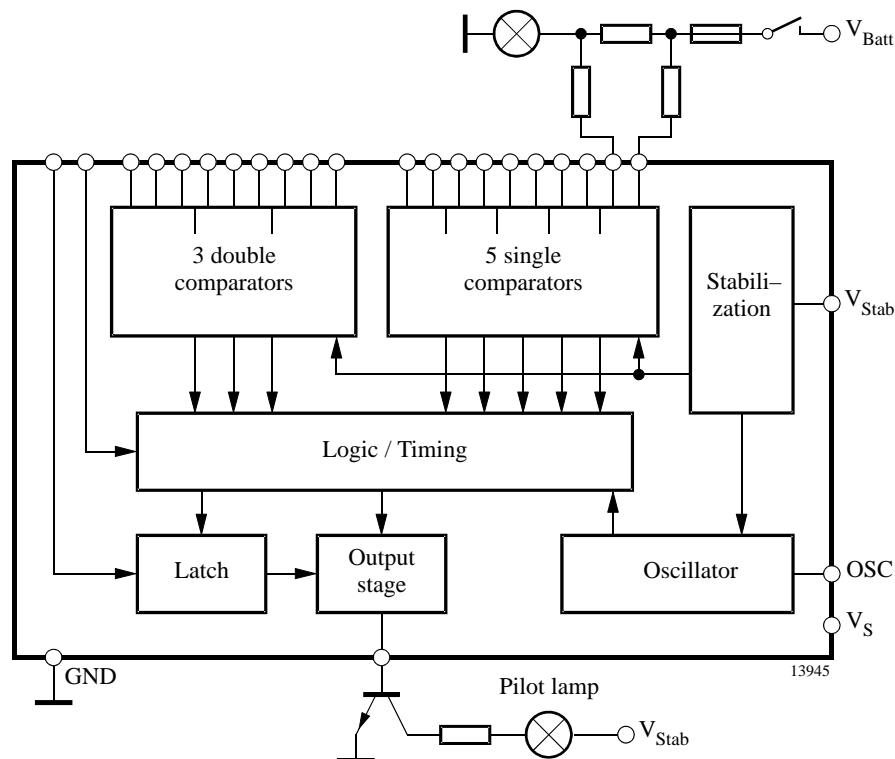

## Detailed Block Diagram

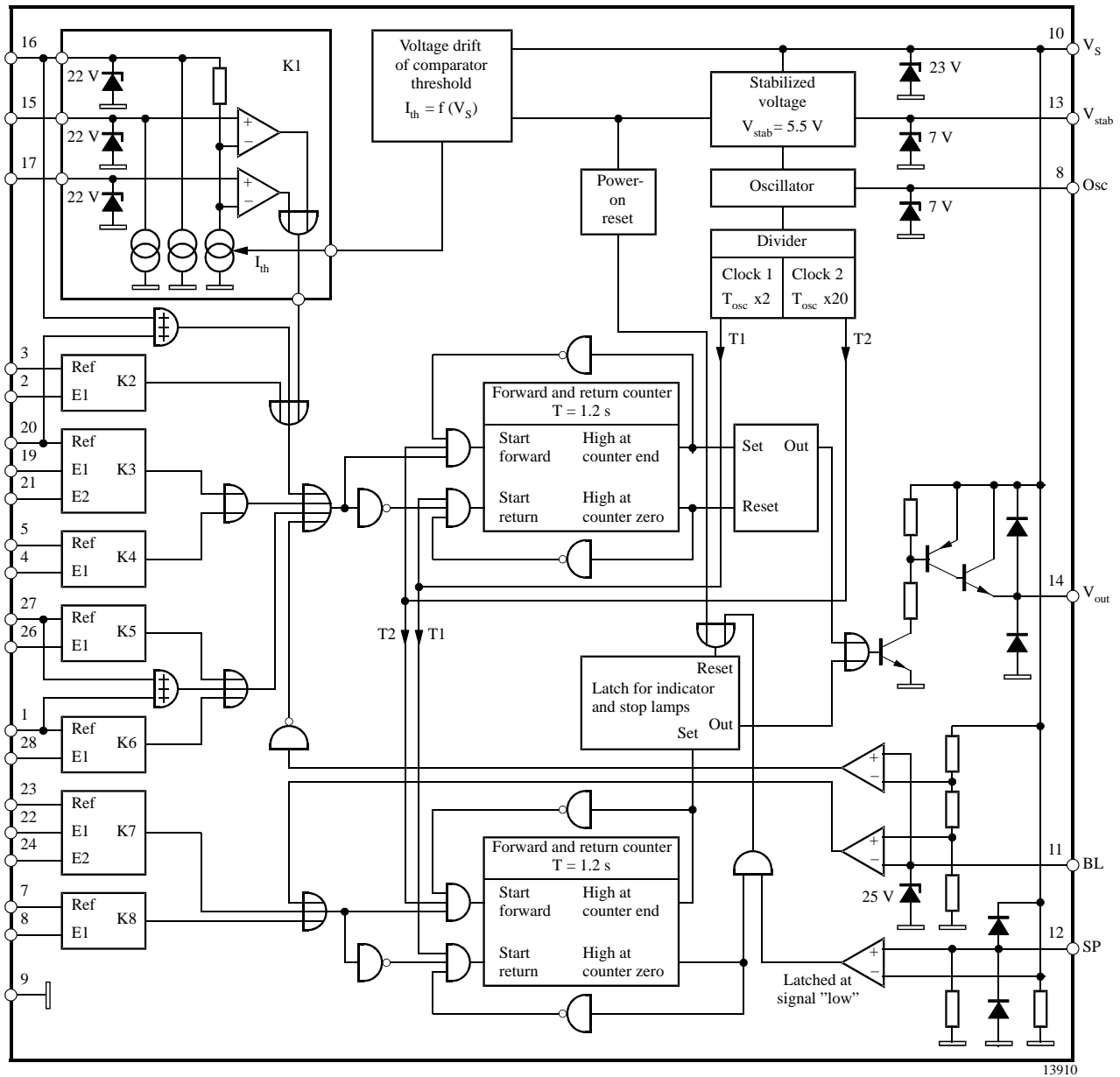

Figure 1. Block diagram

## Pin Description

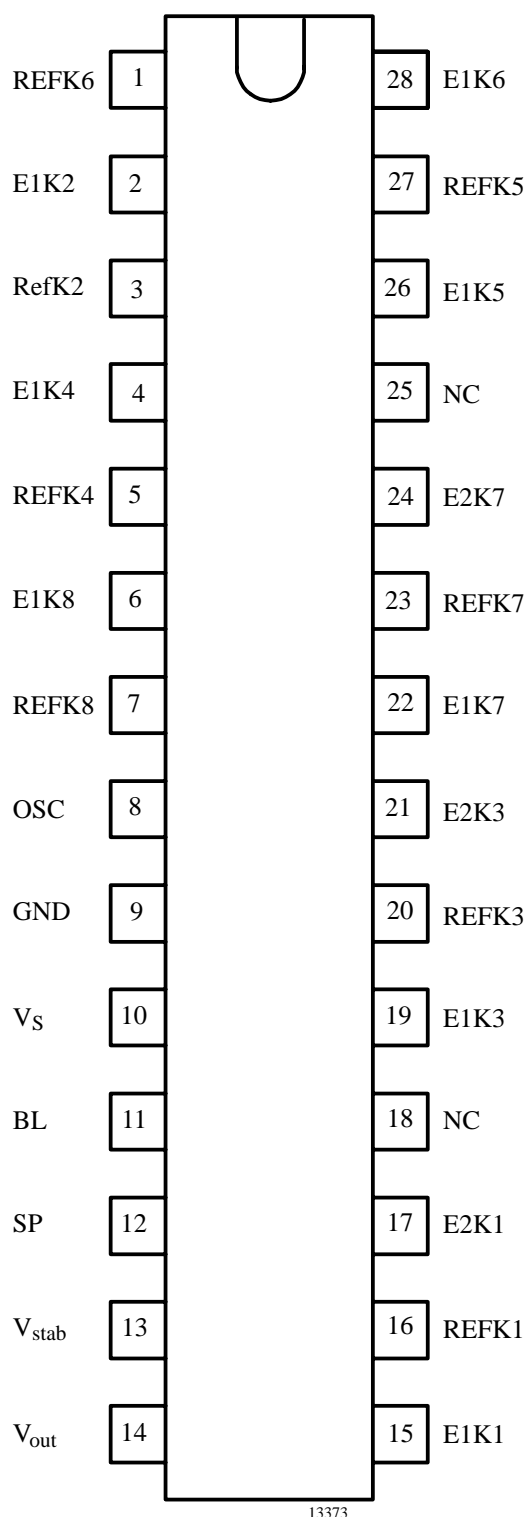

Figure 2. Pin configuration

Pin	Symbol	Function
1	REFK6	Reference for threshold voltage single comparator K6
2	E1K2	Input 1; single comparator K2
3	REFK2	Reference for threshold voltage; double comparator K5
4	E1K4	Input 1; single comparator K4
5	REFK4	Reference for threshold voltage; double comparator K4
6	E1K8	Input 1; single comparator K8
7	REFK8	Reference for threshold voltage; triple comparator K8
8	OSC	Oscillator input
9	GND	Ground
10	V <sub>S</sub>	Supply voltage
11	BL	Input window comparator for direction indicator
12	SP	Programming pin for memory function
13	V <sub>stab</sub>	Stabilized voltage
14	V <sub>out</sub>	Output for tell-tale lamp
15	E1K1	Input 1; double comparator K1
16	REFK1	Reference for threshold voltage; double comparator K1
17	E2K1	Input 2; double comparator K1
18	NC	Not connected
19	E1K3	Input 1; double comparator K3
20	REFK3	Reference for threshold voltage double comparator 3
21	E2K3	Input 2; double comparator K2
22	E1K7	Reference for threshold voltage; double comparator K7
23	REFK7	Reference for threshold voltage double comparator 7
24	E2K7	Input 2; double comparator K7
25	NC	Not connected
26	E1K5	Input 1; single comparator K5
27	REFK5	Reference for threshold voltage single comparator 5
28	E1K6	Input 1; single comparator K6

## Functional Description

### Comparators

The voltage threshold of all internal comparators has a typical value of  $V_{th} = 10 \text{ mV}$ .

A voltage drop across the shunt of  $V_{sh} \geq V_{th}$  means no fault in the lamp circuit and the output is disabled.

In the event of a voltage drop  $V_{sh} \leq V_{th}$ , the output supplies the current  $I_O$ , and the pilot lamp is activated by the external transistor.

The output is reliably disabled for a voltage at the reference pin of the comparators of  $V_{minRef} \leq 1/3 V_S$

The typical values of the input currents are  $25 \mu\text{A}$  and are equally large at the switch-over instant, thus making it possible to connect protective resistors in series. The internal threshold is independent of the value of the protective resistor as long as all resistors of a comparator have the same value.

### Fuse Monitoring

It is possible to monitor the fuses of the lamp circuits by means of an EXCLUSIVE OR function between K1 and K3 and between K5 and K6.

If the Ref pin of K1 (or K5) is low and the Ref pin of K2 (or K6) is simultaneously high, or vice versa, a fault is indicated.

Simultaneous failure of both fuses is not detected.

A fuse is faulty if the input voltage at the pin Ref falls below the voltage  $V_{minRef}$  ( $1/3 V_S$ ).

### Time Delay

A fault is indicated only if it is present for  $t_d = 1.2 \pm 0.2 \text{ s}$ . If an OK pulse  $\geq 100 \text{ ms}$  occurs during this time, time counting is reset to "0". An OK pulse is generated if the comparators K1 to K8 and the input BL do not signal a fault.

A periodic fault signal (period of less than 1 s) is indicated only if the mark-to-space ratio is  $\geq 10/1$ , whereby the

pulse time corresponds to an item of fault information. The time delay until the fault is indicated exceeds the time  $t_d = 1.2 \text{ s}$  in this case.

### Storage

A failure in the break light circuit which is present for longer than  $t_d$  is stored.

A voltage of  $V_{BL} \leq 0.15 V_S$  which is present at the input BL for longer than  $t_d$  leads to fault indication with storage. This allows the possibility of additional flashing monitoring.

A voltage of  $V_{BL} \geq 0.2 V_S$  and of  $V_{BL} \leq 0.65 V_S$  which is present at the input BL for longer than  $t_d$  leads to fault indication without storage. It is thus possible to extend the scope of monitoring beyond 11 lamps by means of additional comparators ICs.

A voltage of  $V_{BL} \geq 0.7 V_S$  at the input BL does not cause a fault signal.

The turn indicator and the brake light memory is maintained by  $V_S$  (terminal 15)

### Power-on Reset

When  $V_{Batt}$  (terminal 15) is applied to Pin  $V_S$ , a brief signal is produced which generates the power-on reset. As a result, the turn indicator, the brake light memory and the counters are reset.

### Outputs

A fault signal at the comparators K1 to K8 or at the comparator Pin BL enables the output so that current  $I_O$  can flow. The output blocking voltage ( $V_S - V_{out}$ ) is typically 1 V.

### Threshold Testing without Time Delay $t_d$

To connect the input comparators directly to the output pin, a voltage of 6 V at Pin OSC is necessary (omit  $R_{OSC}$  and  $C_{OSC}$ ).

## Absolute Maximum Ratings

Parameters	Symbol	Value	Unit
Supply voltage	$V_S, V_{Batt}$	16.5	V
Pulse current (2 ms)	$I_S$	1.1	A
Short circuit current (reversed battery)	$I_{SC}$	170	mA
Output current	$I_{out}$	-12	mA
Ambient temperature range	$T_{amb}$	-40 to +100	°C

Parameters	Symbol	Value	Unit
Storage temperature range	$T_{stg}$	-55 to +125	°C
Junction temperature	$T_j$	150	°C

## Thermal Resistance

Parameters	Symbol	Value	Unit
Thermal resistance SDIP 28	$R_{thJA}$	75	K/W

## Electrical Characteristics

$V_{Batt}$  (K1. 15) = 10 to 15 V,  $T_{amb}$  = -40 to +95°C, supply series resistors and input protection resistors connected (see figure 1 “Block diagram” and figure 3 “Basic application schematic”) unless otherwise specified.

Parameters	Test Conditions / Pins	Symbol	Min.	Typ.	Max.	Unit
<b>Supply</b>						
Supply current	$V_{Batt} = 12\text{ V}$ , $V_{out} = \text{low}$	$I_S$			6	mA
Power on reset (POR)		$V_S$	3.5		5.2	V
<b>Comparators</b>						
Comparator input current during switch over	$V_{Batt} = 12\text{ V}$ Pin 2 Pin 4 Pin 6 Pins 15, 16 Pins 19, 21 Pins 22, 24 Pin 26 Pin 28	$I_{K2}$ $I_{K4}$ $I_{K8}$ $I_{K11}, I_{K12}$ $I_{K31}, I_{K32}$ $I_{K71}, I_{K72}$ $I_{K5}$ $I_{K6}$		25		µA
Comparator output current	$V_{Batt} = 12\text{ V}$ Pin 1 Pin 3 Pin 5 Pin 7 Pin 15 Pin 20 Pin 23 Pin 27	$I_{O6}$ $I_{O2}$ $I_{O4}$ $I_{O8}$ $I_{O1}$ $I_{O3}$ $I_{O7}$ $I_{O5}$		-10		mA
Comparator thresholds $V_{thx} = V_{REFKx} - V_{ExKx}$ $x = \text{Pin-No.}$	$V_{Batt} = 12\text{ V}$ $V_{Batt} = 15\text{ V}$	$V_{thx}$ $V_{thx}$	5.0 6.3	10.0 11.4	15.0 16.5	mV mV
Minimum comparator input voltage		$V_{minRef}$		$0.33 \times V_S$		V
<b>Output <math>V_{out}</math> Pin 14</b>						
Output current	$V_S = 12\text{ V}$	$I_{14}$		-10.0		mA
Output saturation voltage	$V_{sat} = V_S - V_{out}$ $I_{out} = -10\text{ mA}$	$V_{sat}$			1.5	V
<b>Protection</b>						
Voltage of Zener diodes	all REFKx and ExKx. pins Pin VS Pin BL Pin $V_{stab}$ and OSC	$V_{Z1}$ $V_{Z2}$ , $V_{ZBL}$ $V_{Z3}$		22 23 25 7		V V V V
<b>Oscillator Pin 8</b>						
Oscillator frequency	$R_{osc} = 82\text{ k}\Omega$ , $C_{osc} = 10\text{ nF}$ ,	$f_{osc}$		1.67		kHz

Parameters	Test Conditions / Pins	Symbol	Min.	Typ.	Max.	Unit
Delay time		$t_d$	1.1	1.2	1.3	s
Debounce time		$t_{db}$	115	125	135	ms
<b>Flashing frequency recognition</b>		<b>Pin BL</b>				
Fault indication with storage		$V_{BL}$			$0.15 \times V_S$	V
Fault indication without storage		$V_{BL}$	$0.2 \times V_S$		$0.6 \times V_S$	V
No fault indication		$V_{BL}$	$0.7 \times V_S$			V
Input current	$V_{BL} = \text{low}$	$I_{BL}$		-3.0		$\mu\text{A}$
<b>Programming pin</b>		<b>Pin SP</b>				
Latch ON		$V_{SP}$			$0.35 \times V_S$	V
Latch OFF		$V_{SP}$	$0.45 \times V_S$			V
Input current	$V_{SP} = 0 \text{ V}$	$I_{SP}$			-6.0	$\mu\text{A}$
Input current	$V_{SP} = 12 \text{ V}$	$I_{SP}$		300		$\mu\text{A}$

## Package Information

### Package SDIP28

Dimensions in mm

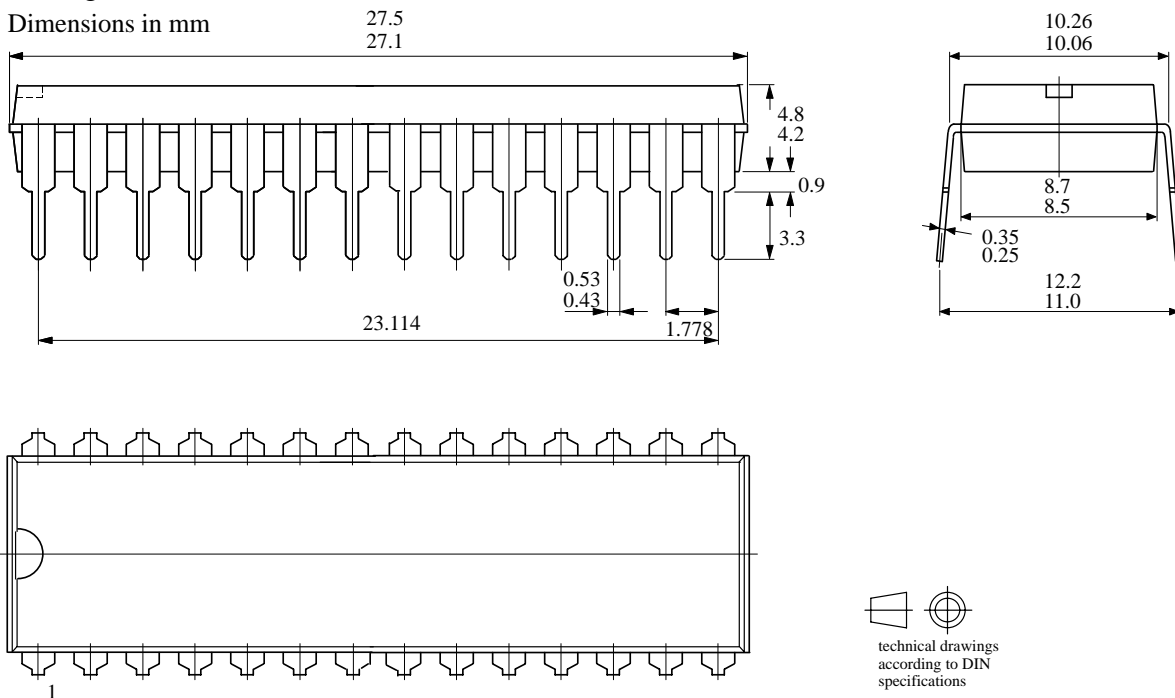

13044

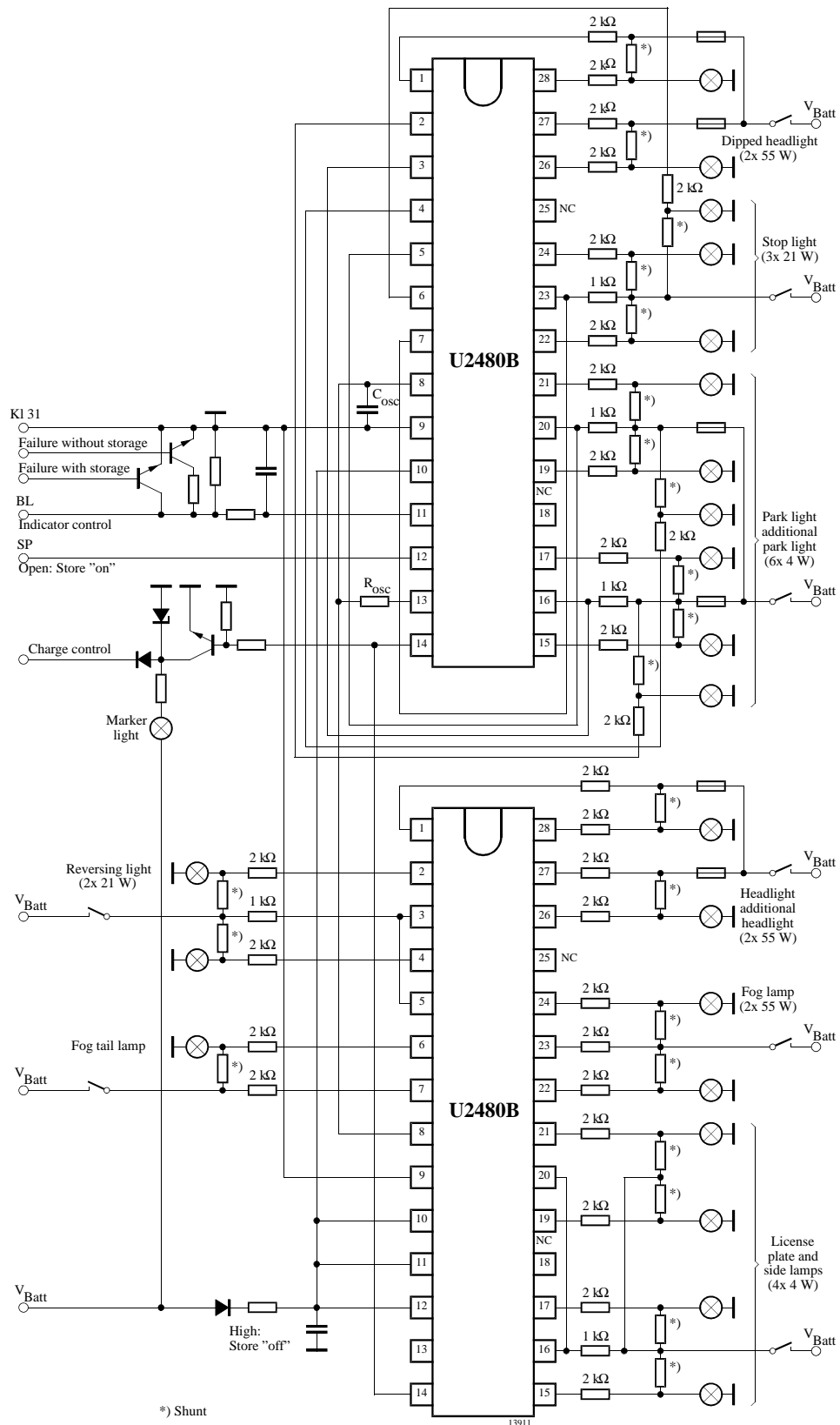

## Ozone Depleting Substances Policy Statement

It is the policy of **TEMIC TELEFUNKEN microelectronic GmbH** to

1. Meet all present and future national and international statutory requirements.
2. Regularly and continuously improve the performance of our products, processes, distribution and operating systems with respect to their impact on the health and safety of our employees and the public, as well as their impact on the environment.

It is particular concern to control or eliminate releases of those substances into the atmosphere which are known as ozone depleting substances (ODSs).

The Montreal Protocol (1987) and its London Amendments (1990) intend to severely restrict the use of ODSs and forbid their use within the next ten years. Various national and international initiatives are pressing for an earlier ban on these substances.

**TEMIC TELEFUNKEN microelectronic GmbH** semiconductor division has been able to use its policy of continuous improvements to eliminate the use of ODSs listed in the following documents.

1. Annex A, B and list of transitional substances of the Montreal Protocol and the London Amendments respectively
2. Class I and II ozone depleting substances in the Clean Air Act Amendments of 1990 by the Environmental Protection Agency (EPA) in the USA
3. Council Decision 88/540/EEC and 91/690/EEC Annex A, B and C (transitional substances) respectively.

**TEMIC** can certify that our semiconductors are not manufactured with ozone depleting substances and do not contain such substances.

**We reserve the right to make changes to improve technical design and may do so without further notice.**

Parameters can vary in different applications. All operating parameters must be validated for each customer application by the customer. Should the buyer use TEMIC products for any unintended or unauthorized application, the buyer shall indemnify TEMIC against all claims, costs, damages, and expenses, arising out of, directly or indirectly, any claim of personal damage, injury or death associated with such unintended or unauthorized use.

TEMIC TELEFUNKEN microelectronic GmbH, P.O.B. 3535, D-74025 Heilbronn, Germany  
Telephone: 49 (0)7131 67 2831, Fax number: 49 (0)7131 67 2423